



# BALKAN OFFROAD RALLYE

25.09 - 30.09.2022

## SUPPLEMENTARY REGULATIONS

VERSION RELEASED ON 09.08.2022

### CONTENT

1. INTRODUCTION	2
2. ORGANISATION	2
3. PROGRAMME	4
4. ENTRIES	4
5. INSURANCE	8
6. ADVERTISING AND IDENTIFICATION	9
7. TECHNICAL REQUIREMENTS	9
8. FUEL	9
9. ADMINISTRATIVE CHECKS	9
10. SCRUTINEERING	10
11. RUNNING OF THE RALLY	11
12. OTHER PROCEDURES	13
13. PRIZES	13
14. PROTEST	13
15. CATERING	14
<i>Appendix 1 Preliminary Itinerary</i>	15
<i>Appendix 2 Race numbers, positioning and advertising</i>	16
<i>Appendix 3 OK / SOS Board</i>	19
<i>Appendix 4 Rally Safety System – Installation and operation manual</i>	20

---

## 1. INTRODUCTION

---

### 1.1 General

RBI SPORT is the organizer of the 10<sup>th</sup> edition of Balkan Offroad Rallye, named for 2022: “Balkan Offroad Rallye 2022” (hereafter named “the rally”), an international event to be held from 25<sup>th</sup> September to 30<sup>th</sup> September 2022.

The rally is organized in compliance with the RBI Sporting Regulations, the Technical regulations, these Supplementary Regulations and Appendices, which supersede all other regulations

Modifications, amendments and/or changes to these Supplementary Regulations will be announced only by numbered and dated Bulletins.

Additional information will be published in the Rally Guide, issued prior to the rally.

RBI Sporting Regulations can be found at [www.balkanoffroad.net](http://www.balkanoffroad.net)

Should any dispute arise as to the interpretation of these regulations, only the Panel of Stewards has the authority to decide.

The organizer reserves the right to interpret, change and supplement these Regulations and to cancel part of the itinerary or the complete rally. The organizer does not take any liability for damages and/or losses and/or harms both occurred to Competitors/Crews and/or their personnel and/or their accompanying persons and/or their equipment and caused by them damages and/or losses and/or harms towards third parties, through the whole duration of the Rally. By submitting the entry form the Competitor/Crews, his personnel and his accompanying persons declare obey to these regulations as well as to traffic rules, fire safety and other applicable regulations at the Rally route and the place of accommodation.

### 1.2 Description of the route

The event will start in Sighisoara, and will finish near Alba Julia, Romania.

The Itinerary is separated in 5 Legs.

The total distance of the itinerary will be approx. 1400 km.

The overall length of Selective Sections will be approx. 1200 km.

Route conditions in Selective Sections: Dirt tracks: 80 %, Gravel: 15%, Tarmac 5 %

The average altitude of the rally is 500 m above sea level.

The Route will be described in a road book (see RBI Sporting Regulations) and the prescribed route will be mandatory. Secret passage controls will be established to ensure compliance.

Selective Sections are run on ‘roads’ open to the public. The greatest care is recommended in relation to other eventual users.

---

## 2. ORGANISATION

---

### 2.1 Organiser, permanent office

RBI SPORT Ltd.  
 St. Peterburg Blvd. 75  
 4006 Plovdiv, Bulgaria  
 Tel.: +359 32 277 993  
 Fax: +359 32 277 990  
 office(at)rbi-sport.com

### 2.2 Approvals

ASN Visa No: TBA.

### 2.3 Trophies for which the Rally counts:

RBI Grand Master Award, Cross Country category

RBI Grand Master Award, Extreme category

## 2.4 Organisation committee

Chairman:	Alexander Kovatchev – President of RBI Sport
Members:	Costin Fantana – Coordinator RBI Sport Vilena Kovatcheva – Marketing manager Daniela Rousekova – Rally administration manager Konstantin Panayotov – Route manager Kamil Jablonski – Rally Control Manager Achim Lust – Safety & Recovery Paolo Baraldi - Media

## 2.5 Panel of Stewards

Chairman:	Ivan Marinov
Members:	TBA Kamil Jablonski

## 2.6 Senior officials

Clerk of the Course:	Alexander Kovatchev
Assistant Clerk of the Course	Costin Fantana
Deputy Clerk of the Course	Marko Misson
Secretary of the Event	Daniela Rousekova
Chief Safety Officer	Adi Moldovan
Chief Scrutineer	Jürgen Teichert
Chief Medical Officer (CMO)	Dr. Artur Gawlowski
Chief Timekeeper	Yoana Marinova
Competitor Relations Officer (CRO)	Georgi Kovatchev
Press Officer	Paolo Baraldi
Environmental Officer	Denis Koch

## 2.7 HQ location and contact details

“Rally HQ” (Rally Office) will be at the competitors’ disposal to assist with information. It will be placed in the centre of the bivouac and will be clearly marked.

Opening and closing work hours will be noticed in the Official rally guide.

## 2.8 Official website

[www.balkanoffroad.net](http://www.balkanoffroad.net)

## 2.9 Digital notice board (DNB)

There will be no physical Official Notice Board at the Rally HQ.  
The Official Notice Board is the SPORTITY Application on mobile phones and tablets.  
“Push” notifications show any new document which is posted on the Digital Notice Board

Sportity app is available in

Available on the App Store

Get it on Google play

There will be no physical Official Notice Board at the Rally HQ. The Official Notice Board is the SPORTITY Application on mobile phones and tablets.

The Sportity App can be downloaded from Google Play or AppStore.

Download from AppStore:

<https://apps.apple.com/ee/app/sportity/id1344934434>

Download from Google Play:

<https://play.google.com/store/apps/details?id=com.sportity.a>

The password is BALKAN2022.

“Push” notifications show any new document that is posted on the Digital Notice Board.

**2.10 Media centre**

Details will be published in the Official rally guide

**3. PROGRAMME**

27 November (Saturday)   09:00h	- Opening date for entries - Online entry list	Official website
10 August 2022 (Wednesday)	- Publishing of the Supplementary Regulations	Official website
31 August 2022 (Wednesday)   23:59 h	- Closing date for online entries	Official website
05 September (Monday)	- Issuing of the Rally Guide	Official website
23 September 2022 (Friday)   from 12:00 h	- Opening Bivouac 1	Camp 1
23 September 2022 (Friday)   from 13:00 h – 19:00 h (Break: 15:30 – 16:00 hrs.)	- Opening Rally HQ - Collection of material and documents - Administrative check - Collection of rally safety tracking system - Scrutineering by time slots	Camp 1
24 September 2022 (Saturday)   from 08:30h to 19:30h Breaks: 10:30 – 11:00 hrs.; 12:30 – 13:30 hrs.; 16:00 – 16:30 hrs.	- Collection of material and documents - Administrative check - Collection of rally safety tracking systems - Scrutineering by time slots - Opening Press Center - Media Accreditation	Camp 1
24 September 2022 (Saturday)   TBA	- Road book collection for Qualifying stage	
24 September 2022 (Saturday)   21:00 h	- Drivers' briefing (mandatory)	Camp 1
24 September 2022 (Saturday)   21:00 h	- Publication of start list for Qualifying stage	Digital Notice Board
25 September 2022 (Sunday)   TBA	- Ceremonial start	Camp 1
25 September 2022 (Sunday)   TBA	- Qualifying stage	Camp 1
25 September 2022 (Sunday)   TBA	- Drivers' briefing	Camp 1
26 September (Monday)	- Leg 1 - Publication of Start list for Leg 2 Drivers' briefing	Camp 1
27 September (Tuesday)	- Leg 2 - Publication of Start list for Leg 3 - Drivers' briefing	Camp 1
28 September (Wednesday)	- Leg 3 - <b>Moving from Camp 1 to Camp 2</b> - Publication of Start list for Leg 4 - Drivers' briefing	Start - Camp 1 Finish - Camp 2
29 September (Thursday)	- Leg 4 - Publication of Start list for Leg 5 - Drivers' briefing	Camp 2
30 September (Friday)	- Leg 5 - Drivers' briefing	Camp 2
30 September 2022 (Friday)   18:30h	- Publication of Provisional Classification	Digital Notice Board
30 September 2022 (Friday) - After the Stewards have declared the Classification final	- Publication of Final Classification	Digital Notice Board
30 September 2022 (Friday)   19:00h	- Prize-giving ceremony	Camp 2
01 October 2022 (Saturday)   12:00h	- Closing Camp 2	Camp 2

**4. ENTRIES****4.1 Opening and closing date for entries**

Opening of entries	27 November 2022 (Saturday)   09:00h
Closing of online Entries	31 August 2022 (Wednesday)   23:59h

**4.2 Entry procedure**

Complies with RBI Sporting Regulations.

By signing/confirming the entry form the Competitor/Crew, its personnel and its accompanying persons submit themselves only to the sporting jurisdictions specified in the RBI Sporting Regulations, as well as the ruling of the following Regulations: Supplementary, Technical and Service, including all appendices.

Admissible drivers and co-drivers are all persons over 16 years of age (the date of the birthday being binding), in possession of a valid driving license for the competition vehicles they want to enter the event.

The organizer reserves the right to refuse the entry to a driver, co-driver, or a service member.

Online entry form must be completely filled out and full entry fees must be paid according to the information specified in these Supplementary Regulations.

**IMPORTANT:** All necessary information regarding the rally will be sent out exclusively in electronic form by e-mail, and for this reason, each participant has the obligation to make known a current and regularly accessed e-mail address in the course of the registration procedure.

The Organizer reserves the right not to validate entries:

- Which have not paid the down payment (deposit) within 4 weeks after submitting the online registration; In this case the online entry will be deleted.
- Who have not fully paid the total amount of the entry fee by the time of the administrative check as specified in the supplementary regulations.
- Entry requests after the closing date of the online registration may be accepted with the approval of the Rally Administration. In this case, contact Rally Administration.

The entry application will be validated at the Administrative Check only if accompanied by:

- Online entry confirmation incl. booking number or entry confirmation by email from the Rally Administration.
- Payment of full amount of the entry fee or copy/document for the fees paid.
- The required documents as per these regulations

All vehicles, also the service vehicles and other wheelers, must have a valid registration and insurance.

#### 4.3 Maximum number of entries

The maximum number of entries that will be accepted is 200. If more than 200 entries are received, the organizer prepares a waiting list and reserves the right to decide which entries will be accepted.

#### 4.4 Eligible vehicles, categories and classes

All vehicles must have valid registration and insurance and to be roadworthy for driving on public roads.

All vehicles must comply with RBI Technical Regulations

The rally is for vehicles with valid or expired FIA/FIM homologation or vehicles without FIA/FIM homologation.

Balkan Offroad Rallye 2022 will have the following categories and classes

CROSS COUNTRY CATEGORY	
<i>Class</i>	<i>subclass</i>
ENDURO	
ATV	
SSV	
CARS	LIMITED
	OPEN

EXTREME CATEGORY	
<i>Class</i>	<i>subclass</i>
CARS	LIMITED
	OPEN

DISCOVERY CATEGORY	
<i>Class</i>	<i>subclass</i>
ENDURO	
ATV	
SSV	
CARS	

**“Discovery” is a non-racing category!**

Minimum 6 vehicles should be registered in one class in order to make a separate ranking. The organizer has the right to combine or cancel classes and subclasses if the minimum number of crews is not reached.

**4.5 Entry fees – 5 days of rally and qualifying stage – rally vehicle, Driver and Co-driver**

CROSS COUNTRY CATEGORY	
ENDURO	1 050 €
ATV	1 050 €
SSV	2 100 €
CARS	2 400 €

EXTREME CATEGORY	
CARS	2 400 €

DISCOVERY CATEGORY	
ENDURO	900 €
ATV	900 €
SSV	1 800 €
CAR 2 persons	2 100 €
CAR 3 persons	2 480 €
CAR 4 persons	2 860 €

For entry requests after the closing date an administrative penalty fee of € 300 must be paid in addition to the Entry fee.

**4.6 Fees – Service Members / accompanying persons and vehicles**

Service member / accompanying person	380 € per person
Small car (up to 3.5t)	130 € per vehicle
Bus/van/camper (up to 3.5t)	150 € per vehicle
Service truck	200 € per vehicle
Trailer (towed by registered service vehicle)	Free
Children Guest package Born 2006 – 2022 WITHOUT administrative service, catering and FAN shop gift	Free
Children Guest package Born 2006 – 2022 WITH administrative service, catering and FAN shop gift	260 € per child

**4.7 Fees and deposits – Rally Safety System**

Rental fees for the Safety Tracking System (incl. vehicle-to-vehicle communication) are included in the entry fees.

**Deposit for safety tracking systems – 350 €**

**Deposit must be paid in cash at the administrative check.**

Deposits are refunded when the equipment is brought back in working condition at the end of the rally.  
Any damage to the equipment must be paid according to the supplier's part list.

**4.8 Down payment**

To validate the registration, every crew must pay the Down Payment (deposit) corresponding to the class in which it is entering, maximum 4 weeks after the entry has been submitted.

The down payment is a part of the total amount.

The RBI reserves the right not to validate registrations if a down payment has not been paid within 4 weeks after submitting the online registration. In this case, the online registration will be deleted.

The Competition number will be issued after receiving the Down Payment (deposit) in the account of RBI.

The Down Payment is refundable following article 4.13.

DOWN PAYMENT FOR ALL CLASSES	
ENDURO, ATV	400 €
SSV / CARS	800 €

#### 4.9 Features included in the entry fee

- Administrative set (ID card, bracelets, stickers etc.)
- Sporting rights (for racing crews only)
- Safety Tracking System rental (for racing crews only)
- Access to rally infrastructure and to service area
- General Third Party Liability Insurance
- Road book (for racers only; no additional costs for roll road book)
- Professional medical assistance
- Recovery service (for racing vehicles only to the closest tarmac road)
- Meals at the bivouac (breakfast, lunch package, dinner) included in the official rally catering
- Sanitary facilities (WC and showers)
- Personal gift from the FAN SHOP
- Award ceremony

#### 4.10 Features NOT included in the entry fee

- Personal Accident Insurance
- Transport of participants and their vehicles
- Fuel
- Personal expenses
- Deposit for “Rally Safety System”
- Flights
- Food and drinks not included in the official rally catering
- Additional costs for PCR and other tests

#### 4.11 Payment terms

To validate the registration, every crew must pay the Down Payment (deposit) corresponding to the class in which it is entering, maximum 4 weeks after the entry has been sent. The down payment is a part of the total amount.

1

Prior to the administrative check, the full total amount of the entry fee must be paid. As a reference participant must enter full name and booking number. The receipt of payment is the decisive date.

IMPORTANT: Participants who pay their entries after the date of the closing of the online entry must show copy/document of the fees paid at the Administrative Check on site.

IMPORTANT: NO BANK CHEQUES WILL BE ACCEPTED!

IMPORTANT: All Bank Charges incurred must be paid by the sender.

IMPORTANT: THE ORGANISER RESERVES THE RIGHT NOT TO VALIDATE REGISTRATIONS OF ENTRANTS:

- Who have not paid the down payment (deposit) within 4 weeks after submitting the online registration; In this case the online registration will be deleted.
- Who have not fully paid the total amount of the entry fee by the time of the administrative check.

Entries after the closing date of the online entry may be accepted with the approval of the Rally Administration. Please contact Rally Administration. In this case the entry application will be validated at the Administrative Check only if accompanied by the total amount of the entry fee (valid for that period) paid on site.

#### 4.12 Invoicing

Invoices will be issued after receiving the payment in our bank account till the end of the running month.

Issued invoices will be uploaded in the competitor's/crew's account in online registration tool till the 10th of the following month (month after the receiving of payment).

Invoices will include the data from the section “Billing” in the online tool.

The mandatory details for issuing the invoice are:

- Full name of the company or the person
- Full address (street, city, country)
- VAT number – (Please fill the correct VAT number if your company has a valid VAT number for European Union (EU). It is possible this VAT number for EU to be different from your local/national number)

Explanation VAT:

- VAT number refers to a number used to identify a company that conducts business in areas over which the European Union has taxation authority.
- All VAT numbers begin with an identifier code that indicates the country that issued the number.
- In the EU, a VAT identification number can be verified online at [http://ec.europa.eu/taxation\\_customs/vies/?locale=en](http://ec.europa.eu/taxation_customs/vies/?locale=en)
- It confirms that the number is currently allocated and can provide the name or other identifying details of the entity to whom the identifier has been allocated.

IMPORTANT: The participants have to fill in the section “Details for invoice” when registering online. It is not possible to update this section once the form has been sent. If you have to change the details please contact: [info@rallye-breslau.com](mailto:info@rallye-breslau.com)

After issuing the invoice no changes are possible anymore.

All the payments will be updated in the Online Registration Tool after the payment has been received in our bank account.

The registered participants can check their balance in the online registration tool using their booking number and password.

#### 4.13 Cancellation and entry fee refunds

Reason	Refund / Reimbursement	Alternative options
The event does not take place on the originally planned dates due to Covid-19 pandemic or other unforeseen circumstances.	See alternative options. Otherwise, the entry fee will be refunded in full, if an alternative option is not chosen by the competitor.	Transfer of paid entry fee to an alternative date or to Fenix Rallye 2023 or Rallye Breslau 2023.
Entry application is rejected by the Organizer.	The entry fee will be refunded in full.	
Team member (driver, co-driver, service member) cannot take part due to duly proved case of medical disability/force majeure including positive PCR test 3 days prior the start of the event.	The team must first look for replacement of the member. If there is no option for replacement and after presenting of a proof for the occurring disability, the entry fee will be refunded in full.	Free of charge transfer of entry to replacing participant.
Participant (driver, co-driver, service member) following the Covid-19 protocol found positive (or having fever) at the entry of the bivouac and quarantined (if applicable).	Driver and/or Co-driver: reimbursement of 30% of entry fee; Service members: reimbursement of 100 Euro of the entry fee.	Free of charge transfer of entry to replacing participant.
Participant (driver, co-driver, service member) following the Covid-19 protocol found positive during the run of the event and quarantined.	No reimbursement possible.	
Cancellation of entry by request from the competitor.	* Reimbursement of 100% of the paid entry fee <b>within 15.07.2022 (Friday). Anyway, the down payment amount will be retained;</b> * Reimbursement of 50% of the paid entry fee <b>within 22.08.2022 (Monday). Anyway, the down payment amount will be retained;</b>	Free of charge transfer of payment to another competitor or transfer of payment to Fenix Rally 2023 or Rallye Breslau 2023

Cancellations and requests for refunds, transfer of payment to substitute participants must be sent in written form to the Rally Administration.

Refunds will be made by 01.11.2022 (Thursday) at the latest.

## 5. INSURANCE

Complies with RBI Sporting Regulations.

The Organization has subscribed a General Third Party Liability insurance policy for sporting event in accordance with the running legislation.

For Balkan Offroad Rallye 2022 the insurance cover extends to the statutory liability:



The insurer's maximum compensation:

- for personal injury, property damage and financial loss is 5.000.000 EUR;
- for bodily injury is 31.000,00 EUR limit for a single person;
- in case of death 15.500,00 EUR for a single person;

This contract assures financial coverage of damages caused to third parties by the Organizer or by the competitors. This insurance gets into effect from 25.09.2022 (Sunday) at 00:00h till 30.09.2022 (Friday) at 23:59h.

This insurance coverage applies only to the Selective Sections of the itinerary, run for best time, achieving the maximum speed. It begins already from entering the Control Zone (yellow sign "notice time control") at the start of a Selective Section and ends with the end of the Control Zone (beige sign "control zone end") at the finish of the Selective Section.

The Organization has subscribed an insurance policy with:

SRC Special Risk Consortium GmbH  
 Belforstr. 15  
 50668 Köln, Germany  
 Phone: +49 221 91409-40  
<https://www.src-net.de/>

---

## 6. ADVERTISING AND IDENTIFICATION

---

Complies with RBI Sporting Regulations.  
 See appendix 2 of these Supplementary Regulations

---

## 7. TECHNICAL REQUIREMENTS

---

The rally complies with RBI Technical Regulations.

The overall technical requirements are a combination of the following:

- The General Technical Regulations
- The Specific Technical Regulations for the vehicle / category
- The Specific Safety Requirements for the vehicle / category
- Additional Specific safety requirements listed in the Supplementary regulations for the event

The combination of all those makes the overall technical regulation for the competing vehicles

Vehicles must have valid road registration and insurance, together with Green Card Certificate, valid for Romania and to be roadworthy for driving on public roads.

The rally does not require FIA or FIM homologation / technical passport of the racing vehicles. Never the less such can help speeding up the scrutineering. There are however several safety and technical requirements which must be fulfilled before entering the scrutineering.

All vehicles must have all their registration plates secured to the vehicles.

---

## 8. FUEL

---

Complies with RBI Sporting Regulations

---

## 9. ADMINISTRATIVE CHECKS

---

### 9.1 Timetable

Drivers, co-drivers, all service members and accompanying persons taking part in the rally must report to the administrative checks in accordance with the rally program.

### 9.2 Documents to be presented with a photo copy:

#### Driver and Co-driver:

- Driver's and Co-driver's passports or identification;
- Driver's and Co-driver's valid driving licenses for the entered vehicle class;
- The total entry fee or copy/confirmation for the fees paid after the closing dates;
- Driver and Co-driver's medical insurance. Complies with RBI Sport Regulations.
- For drivers under 18 years of age, an original letter of consent for participation and a Waiver of Liability from the parents, legalized by a notary and translated in English.

**Rally vehicle:**

- Vehicle's registration certificate;
- Vehicle's insurance cover certificate (green card);
- Car's owner authorization to participate in the rally.

**Service members / accompanying persons:**

- Passport or identification;

**Service vehicle:**

- Vehicle's registration certificate;

During the administrative checks, a Waiver of Liability must be signed and presented to the rally administration.

**9.3 Along the administrative check, competitors will be supplied with:**

- Identification plates
- Advertising stickers
- ID cards / Bracelets
- Scrutineering / Technical check forms
- Hardware for installation of Safety Tracking Systems

---

**10. SCRUTINEERING**

---

**10.1 Scrutineering venue and timetable**

All rally vehicles must report to the scrutineering in accordance with the rally program. A time slot will be assigned during the administrative check.

**10.2 General**

All rally vehicles must comply with the RBI Technical regulations.

The act of presenting a vehicle for Scrutineering is considered an implicit statement of conformity. Scrutineering carried out before the start of the rally will be of a general nature to ensure general conformity with the Category and Classes entered, essential safety items are carried and conformity with the national Traffic Law.

Before a vehicle enters the Scrutineering, it must meet the following requirements:

- have all the required labels fixed (race numbers, advertisement, sun visor, rally plate) according to the Sticker plan.
- have all the required safety tracking elements prepared and installed on the vehicle according to the instructions.
- during scrutineering, all crew members are obliged to present required personal safety equipment and the mandatory equipment in accordance with Technical regulations.

All rally vehicles must report to the scrutineering in accordance with the rally program.

**10.3 Mud flaps (excerpt RBI Technical regulations)**

It is highly recommended for all Cross country category vehicles – SSV and CAR: Mud flaps, covering at least 50% of the wheels (center of the wheel hub) on the back of all wheels.

**10.4 Windows/Nets (excerpt RBI Technical regulations)**

Vehicles with no doors or door windows must have window nets installed. The nets must cover at least 70% of the opening and be readily opened from the top or bottom, from inside and outside the vehicle. The net's mesh size must be no greater than 50mm x 50mm or FIA homologated / expired homologation.

**10.5 Stop lights (excerpt RBI Technical regulations) (not required for Discovery category)**

SSV and Cars: Additional 2 stop lights located separately, minimum 0.75m apart, or 1 additional "big" stop light located in the center, in the upper third of the vehicle, minimum 1.25 meters from the ground, shining to the rear (standard 2 + 1 or 2 additional). Must be visible from the car behind.

**10.6 Installation of Safety Tracking System**

It is compulsory for the Crews to equip their vehicles with Safety Tracking System, for active monitoring and communication with all competing vehicles. The Geotraq Rally Safety System includes live tracking, route & velocity recording and Vehicle-to-vehicle communication.

Geotraq Rally Safety System units will be delivered at the administrative check.

The equipment must be installed by the competitors following the “Geotraq Self-installation manual”. See appendix 3 – Self – Installation Manual.

Competitor/Crew, who during scrutineering presents damaged / non-properly mounted / non-operating wires, is obliged to remove the damage and / or failure before the end of Scrutineering.

Any Crew with a vehicle without properly mounted and fully operational GPS Tracking safety system unit, will not be authorized to start.

The rental fee of the Geotraq Rally Safety System unit is included in the entry fee. A deposit must be paid at the administrative check. Installation and operation manuals are published in appendix of these Regulations.

### 10.7 Garmin GPS device

All competition vehicles must have a working Garmin GPS device with tracking function turned on, at all times during the running of the Leg.

The devices must comply with RBI General Technical Requirements (Appendix 3)

### 10.8 Scrutineering, mandatory documents

- All documents supplied by the organization at the administrative check
- SOS / OK Board – (DIN A3 Format) – Mandatory for all competitors to be printed out by themselves and be available in the vehicles! - See attached appendix 03

[OPEN LINK TO DOWNLOAD THE FILE](#)

---

## 11. RUNNING OF THE RALLY

---

### 11.1 General

Complies with RBI Sporting Regulations

### 11.2 Road sections and Selective sections

**The route of the Rally is composed of Road Sections with a targeted driving time, open for road traffic, and Selective Sections on roads/areas open for the traffic.**

### 11.3 Reconnaissance

As from the publication of the Supplementary Regulations, the presence of a competitor, or anyone connected with a competitor, on any part of the itinerary of an event is prohibited.

### 11.4 Re-start after retirement

Any crew which has failed to complete a Selective Section will be assumed to Re-start the event from the start of the next Leg, unless they confirm otherwise in writing to the Clerk of the Course.

The crew may nevertheless be allowed to Re-start from the next Selective Section after approval from the Clerk of the Course following their due times and maximum permitted lateness.

This shall apply to any vehicle which has not been classified on the grounds of exceeding the time limit or has failed to report to a control, but shall not apply where the vehicle has been disqualified for breach of eligibility requirements, traffic infringements or by a decision of the Stewards.

### 11.5 Check-in procedure (excerpt RBI Sporting Regulations)

Complies with RBI Sporting Regulations

Any difference between the actual check-in time and the target check-in time shall be penalized as follows:

- For late arrival: 10 seconds per minute or fraction of a minute
- For early arrival: 1 minute per minute or fraction of a minute

### 11.6 Permitted early check-in (excerpt RBI Sporting Regulations)

At the time control at the end of a leg (check out control), crews are authorized to check-in ahead of the time without incurring a penalty. Additional time controls with permitted early check-in will be published in the itinerary.

### 11.7 Maximum permitted lateness at a TC (excerpt RBI Sporting Regulations)

At a Time Control, any lateness exceeding 30 minutes of any individual target time will result in the competitor concerned being

considered to have retired at that control, and the competitor will receive a Fixed Penalty. If this occurs at the last Time Control of a leg, the competitor will be penalized with a missed TC only. In calculating such lateness time, the actual time and not the penalty time (10 seconds per minute) applies. The crew may nevertheless re-start the rally under the provisions specified in these regulations.

**11.8 Maximum permitted lateness at a Passage control and Finish of Selective Section (excerpt RBI Sporting Regulations) At a Passage Control and finish of a Selective Section, any lateness exceeding the maximum permitted lateness (MPL) will result in the competitor concerned being considered to have retired, and the competitor will receive a Fixed Penalty. The crew may nevertheless re-start the rally under the provisions specified in these regulations.**

The maximum time for the finish control of the Selective Section will be mentioned on the time card.

#### 11.9 Road books delivery

The collection of Road book for Qualifying stage and Leg 1 will be according to the rally program

The collection of Road books for the next Legs will be at the last time control (check out) of the running Leg.

#### 11.10 Official time and distance used during the rally

The official time of the rally is the GPS time at the place where the rally is held (Romanian time = UTC/GMT+3 (summer time) – CEST). The time measurement accuracy of the Selective Stage is 1 second.

The official distance calibration is a nominal kilometer measured by a GPS device.

#### 11.11 Procedure at the start of a Selective Section (excerpt RBI Sporting Regulations)

Complies with RBI Sporting Regulations

At each Start, there will be electronic starting device with green light. The device may be coupled with a photocell responsible for detection of false starts. The photocell will be placed about 50 cm beyond the start line.

The display will be placed so to be well visible to a Crew sitting in a vehicle on the starting line.

The vehicle with the Crew is placed at the start line. The starting device continuously counts down the last 10 seconds to the moment of the green light. Numbers are shown in the sequence: 10, 9, 8, 7, 6, 5, 4, 3, 2, 1 and the green light. The green light will stay on for 5 seconds. Within 20 seconds from the start of the green light, the Crew must start.

#### 11.12 Qualifying Stage (QS)

##### Running of a Qualifying Stage

The rally itinerary includes a Qualifying Stage

The starting order for the Qualifying Stage is according to the Sporting Regulations of RBI Sport.

It will take place at the beginning of Leg 1/Section 1 as the first Selective Section (SS1A) and all competitors must take part therein. Only one Qualifying Stage may be organized, and it determines the starting order for the start of the subsequent section.

The Qualifying Stage shall be considered as the first Selective Section. The next Selective Section of Leg 1 will be numbered SS1B.

##### Characteristics of a Qualifying Stage

It will be run in the form of a Selective Section, representative of the event stages, with a minimum length of 2 km and a maximum length of 20 km.

##### Timing

For the Qualifying Stage, timing will be taken to the tenth of a second. If the event is timed to the second, the tenths of a second are rounded down to the nearest second once the starting positions for the following Selective Section have been determined.

##### Classification

The Qualifying Stage shall count for the classification of the event.

In case of a dead heat, priority will be given to the crew which achieved the time first.

Any road or other time penalties incurred will be taken into account for the general classification and applied the same day but will not affect the starting order for the subsequent section, except for such penalties involving false starts, shortcuts, or other matters which materially affect the competitor's performance on the Qualifying Stage itself.

##### Start order after a Qualifying Stage

Following the Qualifying Stage, the starts for the subsequent section of each class and category shall be given according to the classifications of the Qualifying Stage. At the discretion of the stewards, motorcycles and quads on one hand and SSVs and cars on an other hand, can be merged in starting groups.

##### Penalties

Any competitor who, having started the Qualifying Stage fails to complete it as required by the Regulations, will be given the maximum time for the Qualifying Stage.

Any competitor not having started the QS will be given a penalty of twice the maximum time for the Qualifying Stage.

---

## 12. OTHER PROCEDURES

---

### 12.1 Bivouac control

The bivouac is a closed area, checked and secured, reserved for private use during the rally, whose access is exclusively and uniquely for persons who have been accredited and registered by the Organization, as well as representatives of local public authorities.

Not registered participant and/or vehicles must pay a deposit of 500,- EUR at the camp control in the bivouac. The deposit is refundable upon registration and payment of full entry fees at the Administrative Check.

Cash penalty for not registered persons caught by the control afterwards is 500,- EUR per person. In addition, the Stewards will be informed for further sporting penalties for the Competitor/Crew concerned.

### 12.2. Environmental protection

All the Competitors/Crews, members of their personnel and their accompanying persons are required to observe the Environmental rules an especially use protective sheets against the destruction and pollution of the ground surface with petroleum materials.

Any maintenance work without the required protective sheet under the vehicle found by Organiser, would entail the imposition of a fine up to 100 % of required entry fee or other penalties by decision of the Stewards.

### 12.3. Electronic toll collection system in Romania

Be advised that in Romania there is an active system to buy a Romanian Vignette online. Read more on: <https://www.roviniete.ro/>

---

## 13. PRIZES

---

### 13.1. Location

The prize giving ceremony will take place in the bivouac. All members of the Competitor/ Crew must be present at the prize-giving. Crews who are not present at the prize-giving may forfeit their prizes; however, the final classification will not be modified

### 13.2. Winner Trophies will be awarded to the winners in the following Overall Classifications:

#### Cross Country Category:

- ENDURO – 1<sup>st</sup>, 2<sup>nd</sup> and 3<sup>rd</sup> place
- ATV class – 1<sup>st</sup>, 2<sup>nd</sup> and 3<sup>rd</sup> place
- SSV class – 1<sup>st</sup>, 2<sup>nd</sup> and 3<sup>rd</sup> place
- CARS LIMITED – 1<sup>st</sup>, 2<sup>nd</sup> and 3<sup>rd</sup> place
- CARS OPEN – 1<sup>st</sup>, 2<sup>nd</sup> and 3<sup>rd</sup> place

#### Extreme Category:

- CARS LIMITED – 1<sup>st</sup>, 2<sup>nd</sup> and 3<sup>rd</sup> place
- CARS OPEN – 1<sup>st</sup>, 2<sup>nd</sup> and 3<sup>rd</sup> place

Minimum 6 vehicles should be registered in one category/subcategory in order to make a separate ranking for this category.

---

## 14. PROTEST

---

Complies with RBI Sporting Regulations

The fee for a protest is 1000 EUR, paid in cash together with the logging of the protest.

Protests cannot be handed after the first competitor/crew has left to the course for the next Leg.

Protest for the last rally Leg cannot be handed after 30 min of publishing the provisional classification.

Steward's decision is final and cannot be appealed.

---

**15. CATERING**

---

The Entry includes catering services. Catering starts with a dinner on 24<sup>th</sup> September 2022 (Saturday) and ends with a breakfast on 1<sup>st</sup> October 2022 (Saturday) in the Bivouac. The daily menu consists of a breakfast, take away lunch package (given at breakfast) and dinner.

IMPORTANT: The catering doesn't include drinks, except coffee and tea at breakfast.

BALKAN OFFROAD RALLYE

---

**Appendix 1 Preliminary Itinerary**

---

**PRELIMINARY ITINERARY for CROSS COUNTRY CATEGORY and EXTREME CATEGORY  
TO BE ANNOUNCED**

BALKAN OFFROAD RALLYE

## Appendix 2 Race numbers, positioning and advertising

### Door/side panels

The Organizer shall supply each crew with a set of Number and “Rally” plates bearing the rally numbers as shown below.

#### Number plate sizes:

- Motorcycles and ATV vehicles – 3 plates measuring 15x14cm
- SSV – 2 plates measuring 30x28cm plus 1 plate measuring 16x13cm
- Cars – 2 plates measuring 42x40cm

#### “Rally” plate:

- Motorcycles and ATV vehicles – 1 plate measuring 19x18cm
- SSV – 1 plate measuring 19x13cm
- Cars – 2 plates measuring 42x29cm

#### Sunvisors (only for SSV, Cars and Trucks):

The Organiser shall supply each crew with a 1 sunvisor – measuring 180x8cm

#### Sticker plan:

Throughout the duration of the rally, the plates must be affixed according to the sticker plan. In no case may they cover, even partially, the vehicle's license plates.

#### Cleaning the identification plates:

The crews are obligated to present their vehicle at the first Time Control of each Leg with clean identification plates. Any crew not following this rule will be refused to start and will be reported to the Clerk of the Course for further penalties.

#### Names and flags:

It is recommended to affix the names of the 1st driver and his co-driver(s), plus their national flags, of a height of 30 - 50 mm on both sides of the front wings or front doors of the vehicle.

#### Obligatory collective advertising plates and advertising plates:

The stickerage space reserved for the Organisers obligatory advertising and start numbers are described in the official Sticker Plan that is under no exceptions compulsory for all the participants in the rally (crews, service and press).

Motorcycles and ATV vehicles – 2 plates measuring 12x8cm plus 2 plates measuring 12x12cm

SSV – 2 plates measuring 30x28cm plus 2 plates measuring 20x10cm

Cars – 2 plates measuring 42x40cm plus 2 plates measuring 20x10cm

#### Preliminary Sticker plan:





## RBI SPORT - STICKER PLAN

### ENDURO

- 1 Number plate stickers at the front and to affixed on the lateral sides of the vehicle  
15cm (width) x 14cm (height)- 3pcs
- 2 Collective advertising plates to be affixed on the lateral sides of the vehicle  
12cm (width) x 12cm (height) - 2 pcs
- 3 Rally plate to affixed on the front side of the vehicle  
12cm (width) x 8cm (height)- 1 pcs

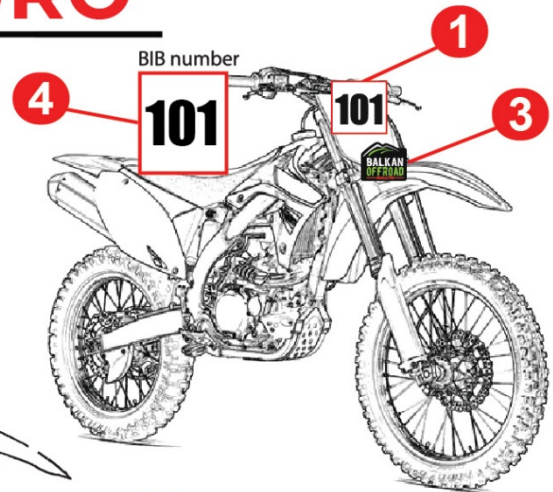
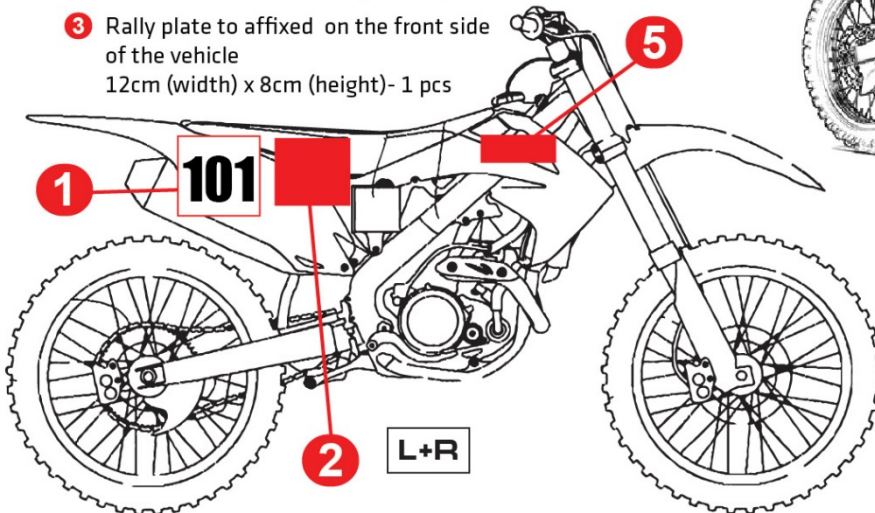

- 4 BIB number 26 x 30 cm - vinyl plate which should be clearly worn on the rider's back. The upper edge of the back bib must be a maximum of 20 cm from the neck of the rider and shall be always visible and not be hidden by anything, like a "Camel Bag".
- 5 Advertising plate  
12cm (width) x 8cm (height) - 2pcs

© RALLYE BRESLAU



## RBI SPORT - STICKER PLAN

### ATV

- 1 Number plate stickers at the front and to affixed on the lateral sides of the vehicle  
15cm (width) x 14cm (height)- 3pcs
- 2 Advertising plates to affixed on the lateral sides of the vehicle  
12cm (width) x 12cm (height) - 2 pcs
- 3 Rally plate to affixed on the front side of the vehicle  
12cm (width) x 8cm (height)- 1 pcs

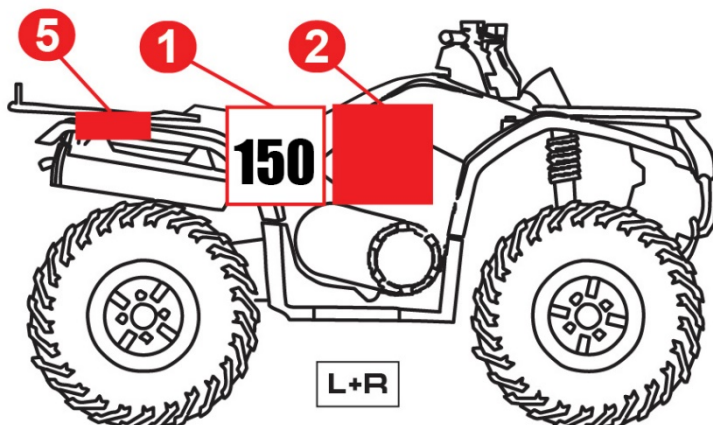

- 4 BIB number 26 x 30 cm - vinyl plate which should be clearly worn on the rider's back. The upper edge of the back bib must be a maximum of 20 cm from the neck of the rider and shall be always visible and not be hidden by anything, like a "Camel Bag".
- 5 Advertising plate  
12cm (width) x 8cm (height) - 2pcs

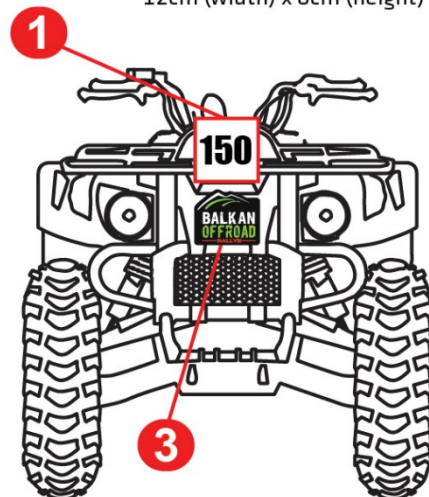

© RALLYE BRESLAU



## RBI SPORT - STICKER PLAN

### SSV

- 1 Number plate stickers to affixed on the lateral sides of the vehicle  
30cm (width) x 28cm (height)- 2pcs
- 2 Sunvisor sticker  
180cm (width) x 8cm (height) - 1piece
- 3 Collective advertising plates  
30cm (width) x 28cm (height)- 2pcs

- 4 Advertising plate  
20cm (width) x 10cm (height) - 2pcs
- 5 Rally plate at the front of the vehicle  
19cm (width) x 13cm (height) - 1 piece
- 6 Number plate  
16cm (width) x 13cm (height) - 1pcs

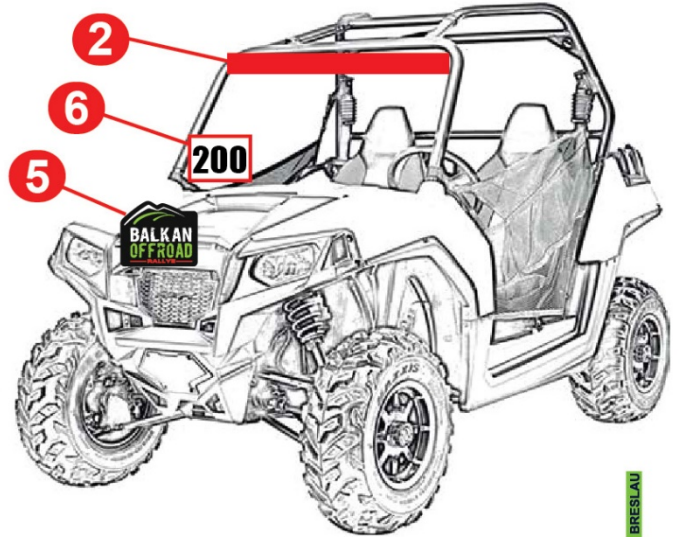
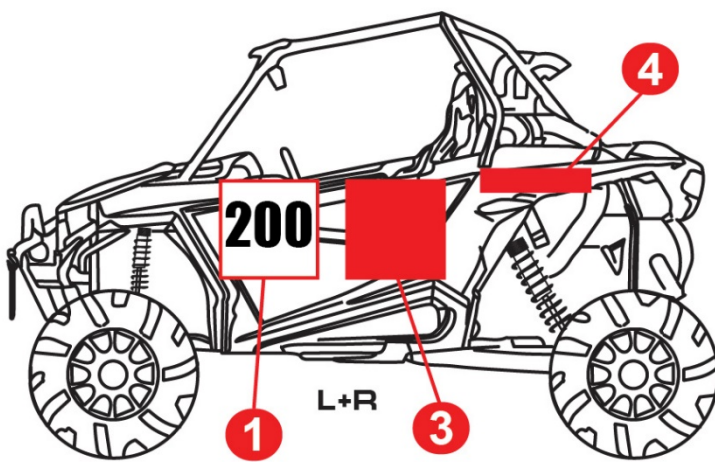

© RALLYE BRESLAU



## RBI SPORT - STICKER PLAN

### CARS

- 1 Number plate stickers to affixed on the lateral sides of the vehicle  
42cm (width) x 40cm (height)- 2pcs
- 2 Sunvisor sticker  
180cm (width) x 8cm (height) - 1piece
- 3 Collective advertising plates  
42cm (width) x 40cm (height)- 2pcs

- 4 Advertising plate  
20cm (width) x 10cm (height) - 2pcs
- 5 Rally plate at the front and rear of the vehicle  
42cm (width) x 29cm (height) - 2 piece

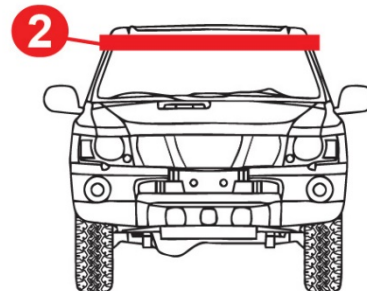
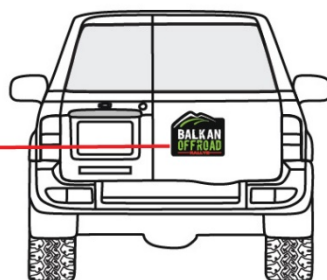
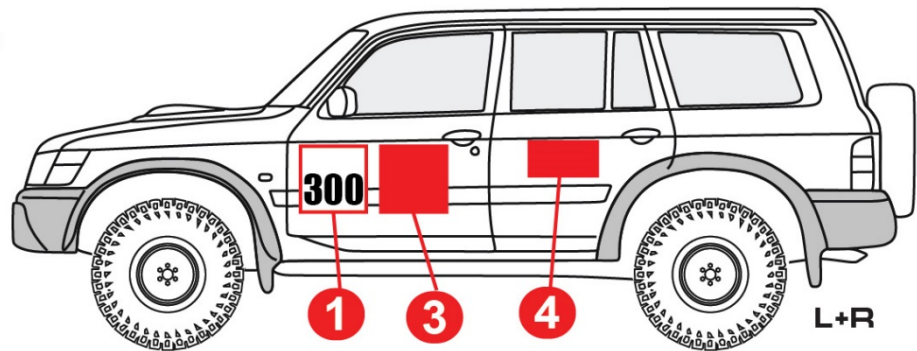
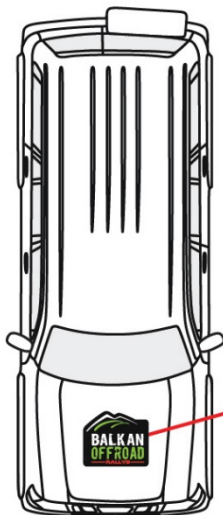

© RALLYE BRESLAU

---

**Appendix 3 – OK / SOS Board**

---

**MANDATORY FOR ALL COMPETITORS**

SOS / OK Board – (DIN A3 Format) – Mandatory for all competitors to be printed out by themselves and be available in the vehicles.

Here you can download the board: <https://rbi-sport.com/Documents/RBI-OK--SOS.pdf>

Please print it in color in A3 format and prepare it as a part of the equipment for the rally.

Overview for illustrative purposes only.



**If you stop on a special stage and DO NOT REQUIRE MEDICAL ASSISTANCE,  
please display this sign prominently!**

  
© Copyright



**If you stop on a special stage and REQUIRE MEDICAL ASSISTANCE,  
please display this sign prominently!**

  
© Copyright



# RALLY SAFETY SYSTEM

**NEW!**

# SELF - INSTALLATION MANUAL

**FOLLOW THE INFORMATION BELOW**

**TO INSTALL THE SYSTEM BEFORE GOING TO SCRUTINEERING**

Version released on 26.07.2022

## STEP 1 – GET FAMILIAR WITH THE SYSTEM COMPONENTS



*NOTE: If needed on CARS and TRUCKS, we can provide additional extension cable to place the radio antenna on a better position.*

- IMPORTANT! NO CUTTING OF CABLES, MODIFICATION OF CONNECTORS OR OTHER INTERFERENCE IN THE SYSTEM COMPONENTS IS ALLOWED! ANY DAMAGE TO THE EQUIPMENT MUST BE PAID ACCORDING TO THE SUPPLIER'S PART LIST!**

## STEP 2 – PREPARE POSITIVE AND NEGATIVE CABLE FROM THE BATTERY TO THE DASH BOARD (SSV, CARS, and TRUCKS) OR THE HANDLE BAR (ENDURO/ATV) AND INSTALL INSULATED TERMINAL CONNECTORS (SUPPLIED BY THE ORGANISATION)

- IMPORTANT! THE BATTERY MASTER CUT-OFF (KILL) SWITCH MUST NOT DISCONNECT THE POWER SUPPLY FOR THE RALLY SAFETY SYSTEM.**
- It is the responsibility of the competitors alone to provide, **DIRECT POWER SUPPLY** from the vehicle's battery according to the drawings provided.
- The power cables **MUST** be "flexible" (multi wire), insulated cables – 2 x **min 0.75** to 1.25 mm<sup>2</sup> (**WITH RED** for positive (+) wire and **BLACK** for negative (-) wire insulation color).
- The connection **MUST** have an **IN-LINE FUSE** - "BLADE TYPE" of 5A.

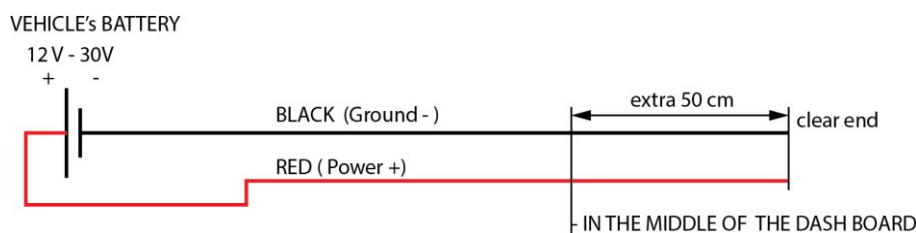

**FEMALE INSULATED  
TERMINAL CONNECTORS**

## STEP 3 – MOUNTING THE SYSTEM - OVERVIEW

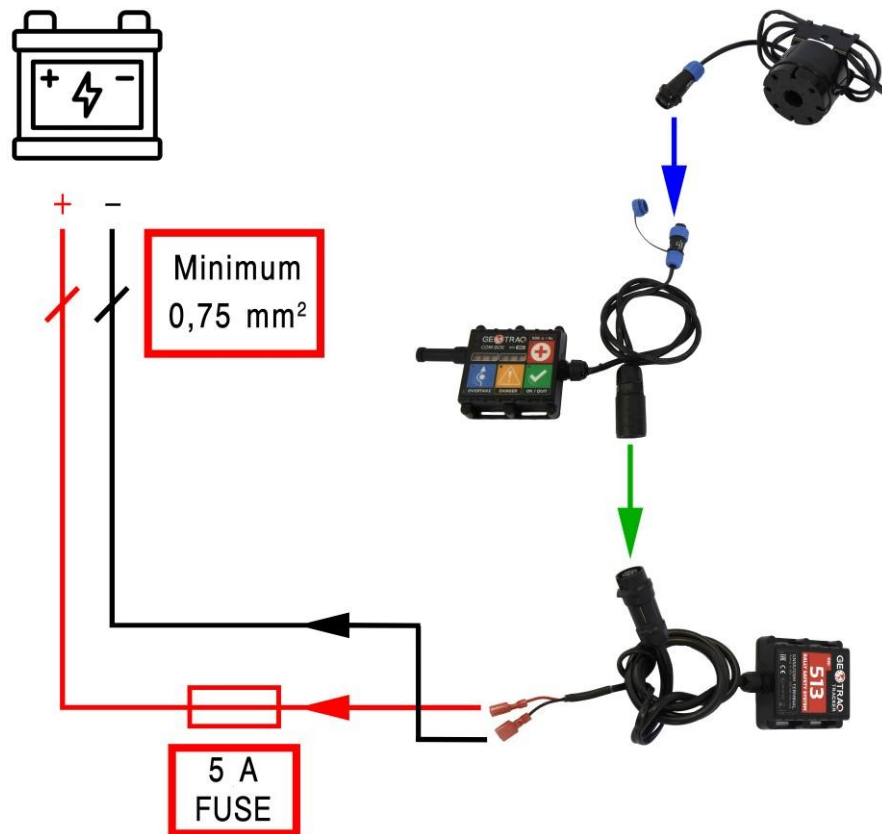

Overview of the system connections.

- You will receive two 6,3 mm female quick plug terminals for the power connection. **If you have old terminals, discard them and use the provided new ones.**

- **IMPORTANT! USE ONLY THE PROVIDED QUICK PLUG TERMINALS! DO NOT USE YOUR OWN!**
- **IMPORTANT! USE PROPER TOOLS TO CRIMP THEM!**



Proper tools for crimping.

## STEP 4 – ORDER FOR CONNECTING THE SYSTEM

During the mounting of the system components you **MUST** follow this order:

- First connect the COM-BOX – TRACKER cable.



*Connect the COM-BOX to the TRACKER.*

- Second the BUZZER – COM-BOX cable.



*Connect the BUZZER to the COM-BOX.*

- Last connect the power supply cables.

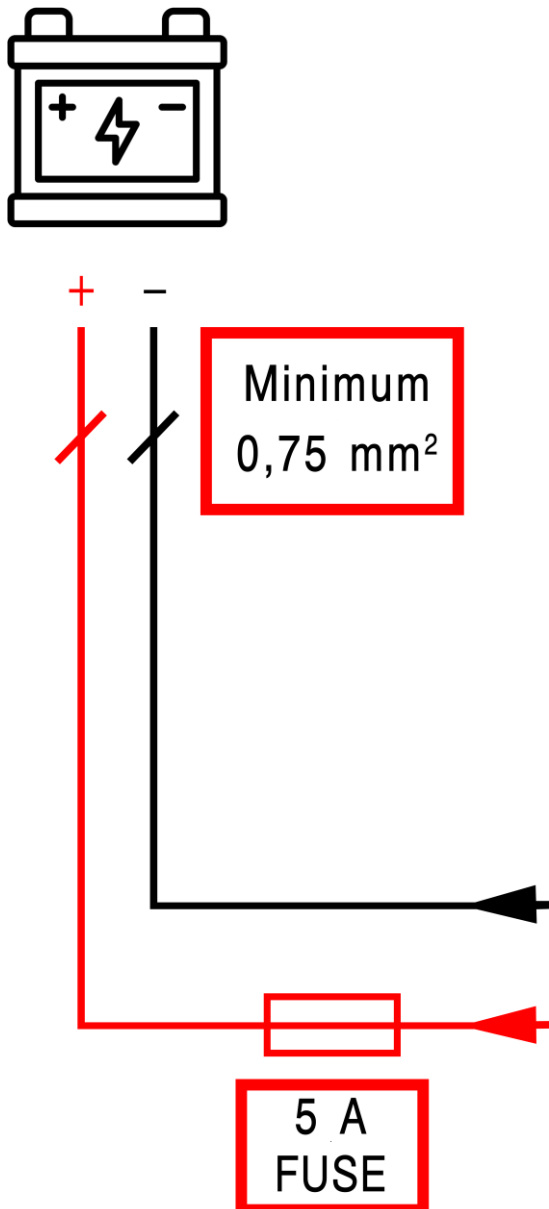

First connect the  
**positive + wire**  
Then connect the  
negative - wire

*Connecting the power supply after everything else has been connected.*

- **IMPORTANT! DO NOT DISCONNECT THE POWER TO THE SYSTEM UNTIL THE END OF THE RALLY!**
- **IMPORTANT! DO NOT OVERUSE CABLE TIES TO SECURE THE CABLES!**



## STEP 5 – MOUNT THE GPS TRACKER ON THE PROPER POSITION

- For ENDURO the best position is at the navigation tower or the top end of the suspension forks.
- For ATV the best position is at the navigation tower or the area around the head light
- For SSV, CARS, TRUCKS, the best position is the “A-pillar” of the roll cage, or the horizontal member of the roll cage, with the tracker facing upwards.

- **IMPORTANT! THE GPS TRACKER MUST HAVE VISIBILITY TO THE SKY (NO METAL ON TOP OF THE DEVICE)**
- **IMPORTANT! INSTALLATION IS DONE WITH CABLE TIES THROUGH THE HOLES OF THE BASE OF THE DEVICE**
- **IMPORTANT! POSITION THE DEVICE IN SUCH A WAY THAT NO DIRECT DAMAGE CAN BE DONE!**



*Installation of the GPS TRACKER on the suspension fork using cable ties.*



*Installation of the GPS TRACKER on the navigation tower using cable ties.*



*Installation of the GPS TRACKER on the railing of ATV using cable ties.*



*Installation of the GPS TRACKER on the roll cage "A-pillar" of a SSV using cable ties.*



Installation of the GPS TRACKER on the roll cage “A-pillar” of a Car using cable ties.

## STEP 6 – MOUNT THE COM BOX MOUNTING BRACKET AND INSERT THE COM-BOX UNIT ON THE PROPER POSITION

- You can bolt the mounting bracket as shown in the graphics below, or you can use industrial grade velcro or double-sided tape to stick it to a good surface or use cable ties to fix it to a central location on the dashboard or to the overhead tube of the roll cage above the centre of the dashboard.
- If needed, additional opening can be drilled to fix it on the required position.
- **IMPORTANT! THE COM-BOX MUST BE IN REACH OF THE DRIVER / CO-DRIVER TO OPERATE THE BUTTONS!**
- **IMPORTANT! ENSURE THERE IS SUFFICIENT SPACE AT THE SIDE OF THE UNIT TO ENABLE THE ANTENNA / EXTENSION TO BE FITTED AND SLIDE THE UNIT INTO THE BRACKET!**

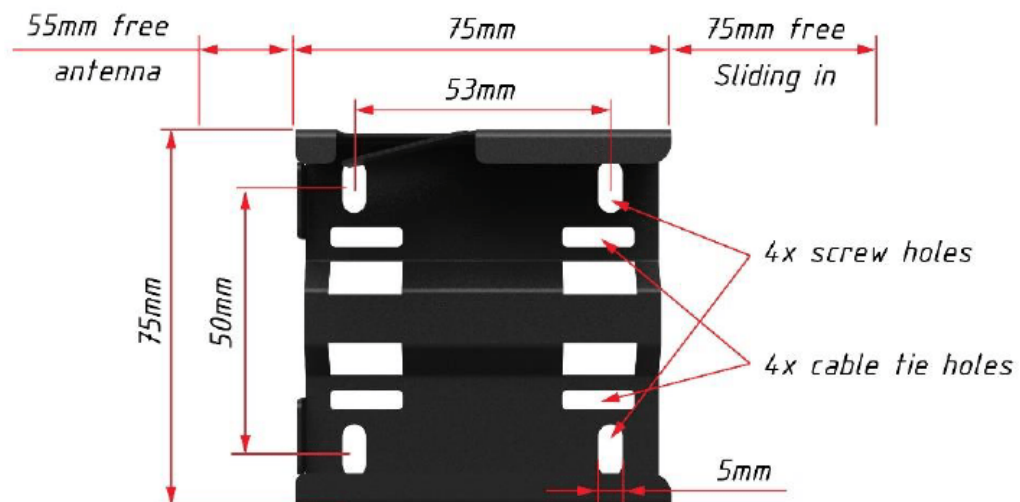



**IMPORTANT: No bolt/screw heads or cable/zip ties can protrude over the red line as marked bellow.**

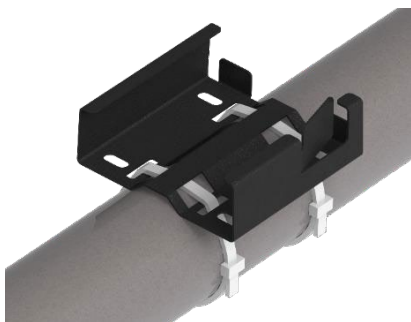
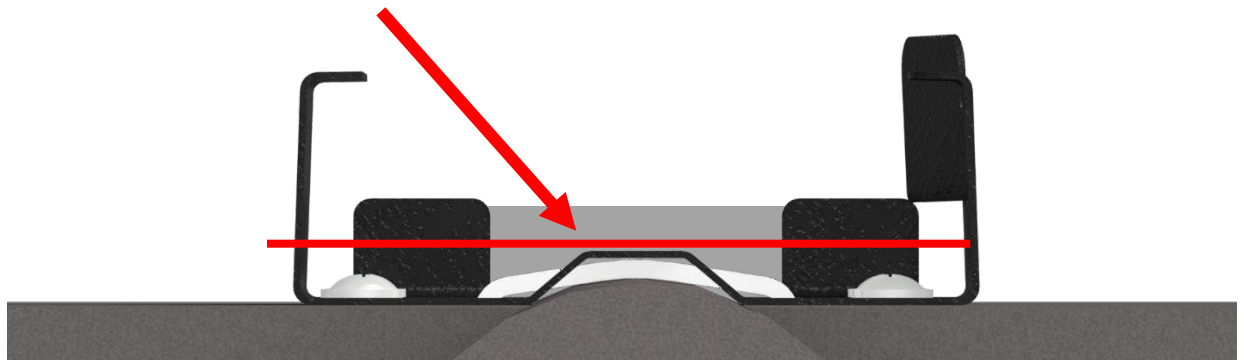

Cable / zip tie fixture

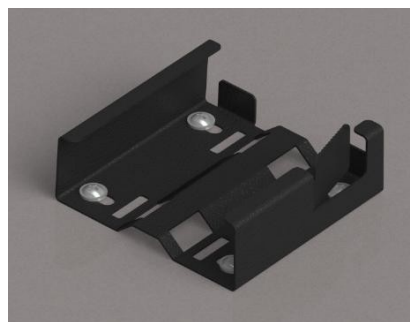

Screw / bolt fixture



Com-Box unit installed in bracket

- When the mounting bracket is securely installed, you can slide-in the Com-Box unit in.



- **IMPORTANT! THE ANTENNA NEEDS AT LEAST 55mm IN ALL SIDES TO WORK PROPERLY! MAKE SURE NOT TO PLACE IT RIGHT NEXT TO OTHER METAL COMPONENTS!**



*Installation of the Com-Box unit with bracket on the handle bar using cable ties.*

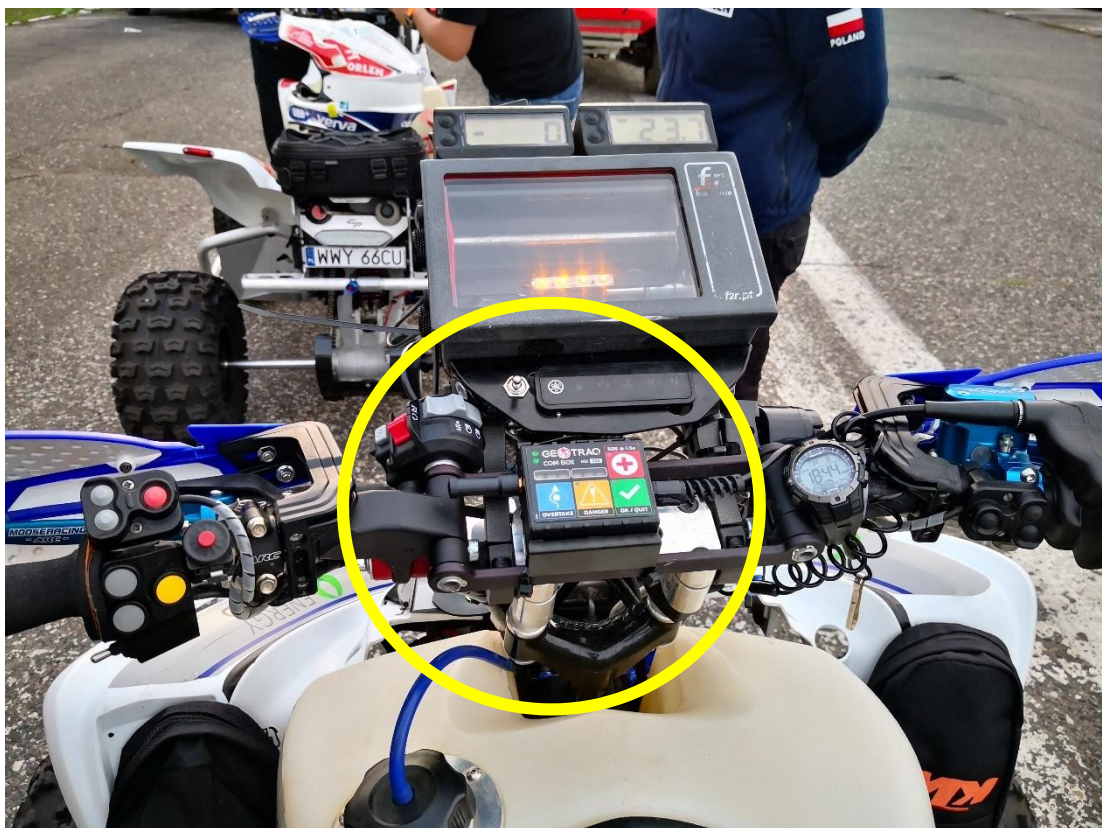

*Installation of the Com-Box unit with bracket on the handle bar using cable ties.*



Installation of the Com-Box unit with bracket on the roll cage using cable ties. **This must be in a CENTRAL location and not as indicated above, only in front of the co-driver.**



Installation of the Com-Box unit with bracket on the dashboard using bolts. **This must be in a CENTRAL location and not as indicated above, only in front of the co-driver.**

## STEP 7 – MOUNT THE BUZZER ON SUITABLE POSITION

- You can use cable ties to fix it to a tube of the roll cage or similar base.
- **IMPORTANT! FOR CARS AND TRUCKS, THE BUZZER CAN BE SUPPLIED WITH ADDITIONAL RADIO EXTENSION CABLE THAT GOES FROM THE COM-BOX UNIT TO THE BASE OF THE BUZZER MOUNT AND THE ANTENNA WILL BE ATTACHED ON THE BUZZER MOUNT.**



*Installation of the Buzzer with bracket on the handle bar using cable ties.*



*Installation of the Buzzer with bracket on the handle bar using cable ties.*



*Installation of the Buzzer with bracket on the Roll cage using cable ties.*



*Installation of the Buzzer with bracket on the Roll cage using cable ties.*



## STEP 8 – CHECK IF THE INSTALLED ANTENNA IS UNDAMAGED AND MOUNTED.

- **IMPORTANT! DO NOT USE FORCE IF TIGHTENING THE CONNECTOR. TIGHT WITH FINGERS ONLY!**

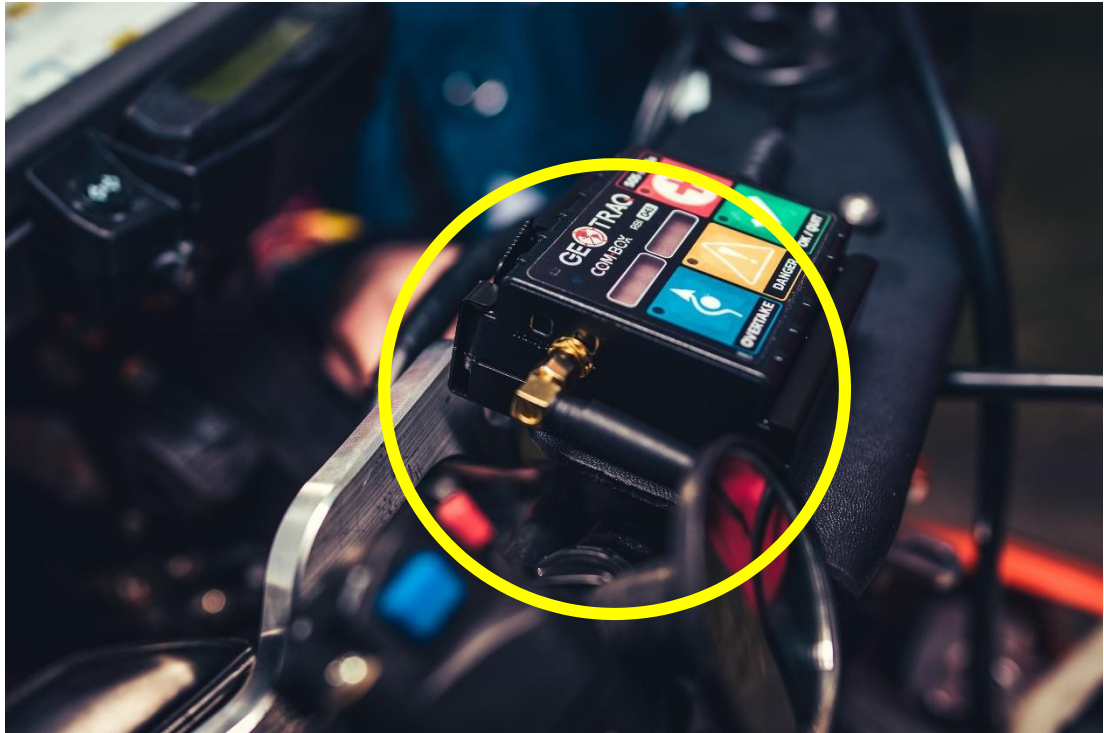

*Installed antenna on the Com-Box unit.*





*Installed antenna on the Buzzer unit (optional only when using extension cable).*

## STEP 9 – CHECK THE STATUS OF THE RALLY SAFETY SYSTEM.



- First, make sure the antenna is connected (optional extension cable and antenna)
- Second, check the blue connectors (buzzer)
- Third, check the connection of the black connectors between the GPS Tracker and the Com-Box unit
- Finally check the connection of the 2 power terminals (positive and negative)

- **IMPORTANT! WHEN CONNECTING THE POWER TERMINAL MAKE SURE YOU HAVE THE PROPER POLARITY – RED is POSITIVE, BLACK is NEGATIVE!**
- **IMPORTANT! IF ALL THE COMPONENTS ARE CONNECTED PROPERLY, THE COM-BOX UNIT WILL DISPLAY A “GREEN STATUS” ON THE BATTERY ICON AND “BLUE/GREEN STATUS” on the RADIO ICON**

### BATTERY STATUS

-  - EXTERNAL POWER
-  - NO EXTERNAL POWER
-  - (BLINKING) INT. BATTERY EMPTY

### RADIO STATUS

-  - RADIO OK
-  - SLEEP MODE, NO RADIO

### OVERTAKE FUNCTION

### DANGER BEACON



### EMERGENCY SOS BEACON

- PRESS AND HOLD UNTIL ACTIVATED

### CONFIRM / QUIT BUTTON

## STEP 10 – FINAL INSPECTION AT SCRUTINEERING

- Install the cables loosely using only a few cable ties and in such a way that they can be clearly checked at scrutineering.
- Only **after** you receive **APPROVAL** from the Scrutineer and/or the GPS Technician, you can fully fasten the cables onto the vehicle using cable ties. **DO NOT** overuse cable ties!

- **IMPORTANT! DO NOT PLACE THE CABLES FOR THE SYSTEM IN DIFFICULT OR HIDDEN PLACES (INSIDE THE DASHBOARD OR HARD TO REACH LOCATIONS). THE INSTALLATION WILL BE CHECKED TO ENSURE THE SYSTEM AND ADDITIONAL COMPONENTS ARE PROPERLY INSTALLED AND OPERATIONAL AT SCRUTINEERING AND IF REQUIRED, YOU WILL NEED TO REROUTE THE WIRING.**

- **DO NOT** use insulating or any other tape to group the cables.

## STEP 11 – WATCH THE VIDEO OF HOW TO USE THE SYSTEM

- On the following link, you can learn how to operate with the Com-Box:

<https://www.youtube.com/watch?v=6hSXuu6DcyE>



## STEP 12 – RETURNING THE SYSTEM

When it's time for you to take off the system from your vehicle you **MUST** follow this order:

- First disconnect the negative (-) wire, then disconnect the positive (+) wire from your vehicle female quick connect terminals.
- Second disconnect the COM-BOX - TRACKER cable
- Third disconnect the Buzzer – COM-BOX cable

- **IMPORTANT! WHEN YOU RETURN THE SYSTEM TO THE CHECKOUT STATION, YOUR EQUIPMENT WILL BE CHECKED FOR DEFECTS AND IF SUCH ARE FOUND – YOU WILL BE SANCTIONED WITH YOUR DEPOSIT MONEY.**